

STARTRITE

GENUINE SPARE PART

A.L.T. Saws & Spares Ltd

Startrite Machine Specialist
Unit 15, Pier Road Industrial Estate
Gillingham
Kent
ME7 1RZ

Tel/Fax: 01634 850833
www.altsawsandspares.co.uk

351SE

SINGLE SPEED
VERTICAL BANDSAW

IMPORTANT
READ THE INSTRUCTIONS
CAREFULLY BEFORE
USING THIS PRODUCT

PC00137

ISSUE 1



QUALITY
BANDSAW
BLADES

TO SUIT THE 351SE MODEL

ORDER LINE- 01634 850833

A.L.T. SAWS & SPARES LTD

Unit 15, Pier Road Industrial Estate

Gillingham

Kent

ME7 1RZ

www.altsawsandspares.com

A.L.T. SAWS AND SPARES LTD



PART NUMBER STRG – UPPER – £82.50+vat
 PART NUMBER STRG – LOWER – £79.50+vat

These precision roller guides are manufactured in the UK specifically for the older Startrite models 301 – 351 – 352, refer to the chart below for all models and recommended blade widths.

There is NO drilling, filing or any modification required unlike many cheap after market guides currently on the market.

Manufactured in steel and aluminium, these guides will make a very good saw even better, they give superb blade control have low heat generation to the blade and produce no sparks.

Both side support rollers and thrust roller are adjusted by a cam system giving precision setting longer, and allows full contact to the blade, this eliminates any blade twist, cutting contours will particularly appreciate the blade control.

Although available as upper and lower guide assemblies some customers may only wish to change the upper set as this takes on 80% of the work.

STARTRITE MODEL	STRG – UPPER RECOMMENDED BLADE WIDTH		STRG – LOWER RECOMMENDED BLADE WIDTH	
	MAX	MIN	MAX	MIN
301,301E,301S	5/8"	1/4"	1/2"	1/4"
351,351E,351SE,351S	3/4"	1/4"	1/2"	1/4"
352,352S	3/4"	1/4"	1/2"	1/4"
RS1 (Sold Under The Record Power Range)	5/8"	1/4"	1/2"	1/4"
RS2 (Sold Under The Record Power Range)	3/4"	1/4"	1/2"	1/4"

CONTENTS

PAGE	DESCRIPTION
4	General arrangement
5	Specification and standard/optional equipment
6	Health and safety advice
7	Handling, transportation and fixing
8	Connection of the electricity supply
8	Connection to a dust extraction system
9	Setting and operating instructions
	<ul style="list-style-type: none">- Adjusting table tilt angle- Adjusting blade guards- adjusting the bandwheel brush- Replacing the table insert- Fitting the blade- Blade tension adjustment- Blade tension indication- Blade tracking- Blade guide adjustment- Adjustment of rip fence- Using the depth stop (optional)- Using the mitre gauge (optional)- Using the circle cutting attachment (optional)- Starting and sawing- Stopping
14	Maintenance
15	Blade and tension selection
	<ul style="list-style-type: none">- Selection of tooth pitch- Selection of tooth form- Selection of tooth set- Selection of blade tension
18	Bandsawing practice
19	Common sawing problems
20	Wiring diagram
22	Parts list
26	Optional equipment

GENERAL ARRANGEMENT

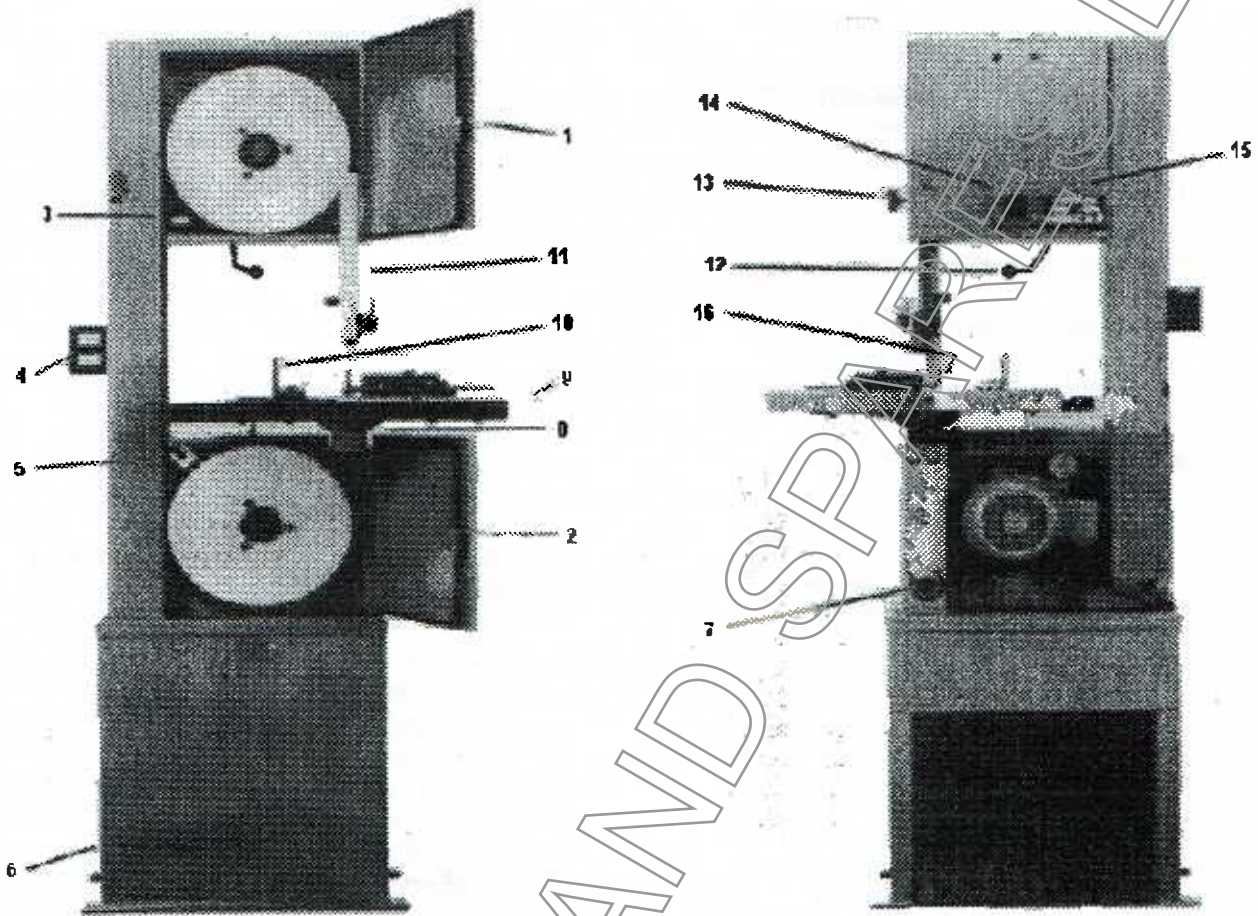

Fig 1

Key

- | | | | |
|---|----------------------|----|-----------------------------|
| 1 | Upper bandwheel door | 10 | Rip fence |
| 2 | Lower bandwheel door | 11 | Upper blade guard |
| 3 | Tension indicator | 12 | Blade tension adjuster |
| 4 | Start/stop switch | 13 | Blade guide adjustment lock |
| 5 | Blade brush | 14 | Blade tracking adjustment |
| 6 | Stand | 15 | Rating/serial number label |
| 7 | Dust extraction port | 16 | Table insert |
| 8 | Lower Blade guard | | |
| 9 | Table | | |

SPECIFICATION

STANDARD/OPTIONAL EQUIPMENT

Electrical Supply	1 phase	230v 50hz
Motor Power	(kW)	1.1
Current	(A)	8
Rating	Int.	TEFV
Motor speed	r/min	2880
Stopping time	(secs)	<10
Height under guides	(mm)	300
Throat depth	(mm)	350
Blade speed	(m/min)	888
Blade length	(mm)	2845
Min blade width	(mm)	3
Max blade width	(mm)	20
Bandwheel diameter	(mm)	355
Table size	(mm)	450 x 450
Table tilt angle		0 - 45
Weight		98 Kg
Sound power*		< 90

Reversible rip fence
 Blade
 Instruction manual
 Tools
 Depth stop
 Mitre fence
 Circle cutting attachment
 Stand



● standard equipment
 ○ optional equipment

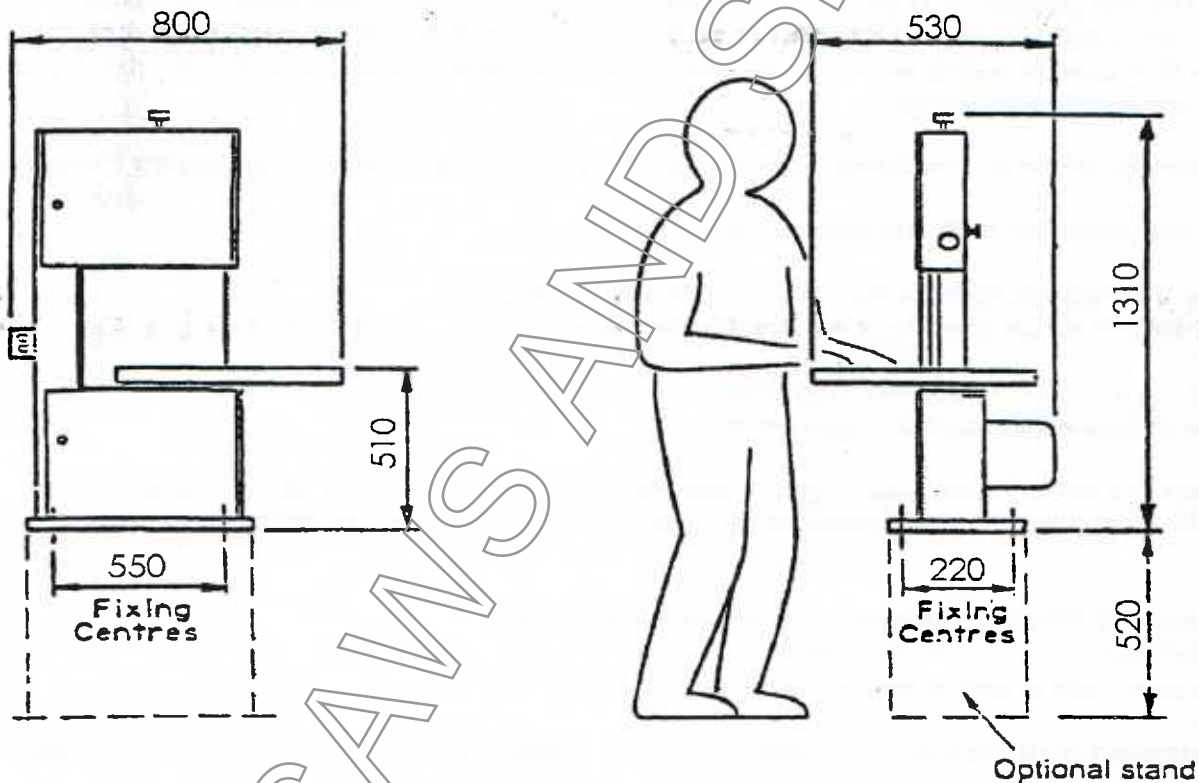

All dimensions are in mm and are approximate.

Due to the policy of continuous product improvement specification may change without notice.

* The sound power levels quoted are emission levels and are not necessarily working levels. Whilst there is a correlation between emission levels and exposure levels, this cannot be used reliably to determine whether or not further precautions are required. Factors that influence the actual level of exposure of the work force include the duration of exposure, the characteristics of the work room, and other sources of noise. Also permissible exposure levels can vary from country to country. However, this information will enable the user of the machine to make a better evaluation of the hazard and risk.

HEALTH AND SAFETY ADVICE

Read the instructions carefully before using this product.

This machine should be bolted down to a rigid, stable structure at a comfortable working height in a well lit, well ventilated, uncluttered area with a non slippery floor.

The machine is isolated by disconnecting the plug from the power supply. Ensure that the plug is easily accessible for quick removal, and beware of the risk of tripping over the cable or the dust extraction hose when fitted.

Avoid wearing loose clothing, ties, loose sleeves etc.

Long hair should be covered or tied back.

Eye protection should be worn when operating this machine.

It is always advisable to wear ear protection, and it is essential when cutting resonating materials.

We strongly recommend the use of a dust extractor and visor. When a dust extractor is not used, always use a dust mask when operating and cleaning the machine. The fine particle dust produced in sawing operations of most materials, particularly hardwoods and asbestos can be a health hazard. A port is provided on the machine for the connection of a suitable extractor, our Customer Service Department will be happy to advise you on the current unit for your needs.

Before opening either of the bandwheel doors, isolate the machine by unplugging from the mains.

Never run the machine with the door open.

Ensure that the blade is suitable for the work to be undertaken.
Do not use blades which have become blunt or damaged.

Avoid touching a hot blade immediately after the sawing operation.
Always use gloves when handling saw blades.

Always lower the upper blade guide / guard assembly as close as possible to the workpiece.
The lower blade guide and guards should be positioned as close as practical to the underside of the table.

Use the pushstick provided when working close to the blade.
Never place fingers in line with the blade.
Ensure the pushstick is within reach before starting a cut.

Before attempting to release jammed material / blade, switch off and disconnect from the power supply.

Disconnect from the power supply before making any adjustments or cleaning the machine.

Never leave the machine running when not in use.

Do not expose to rain or use in damp locations.

This machine is not suitable for use in potentially explosive environments.

Cultivate safe working habits by practising the above mentioned safety measures.

HANDLING, TRANSPORTING AND FIXING

Damage caused by incorrect handling, transportation or installation may invalidate the guarantee. Consequently if in doubt about the safe handling or installation of the machine obtain the services of a competent technician,

When transporting this machine do not strap across the table or over the top of the machines (see fig 2a and 2b). Always locate retaining straps over the lower wheel box beneath the table (fig 2c).

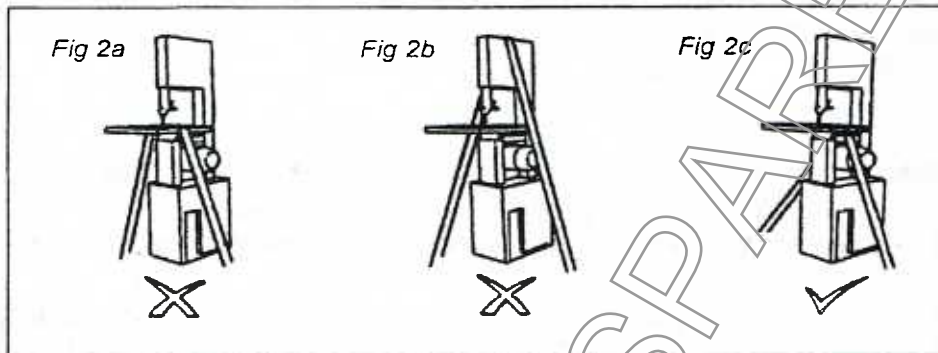

To minimise the risk of damage it is recommended that the machine be transported with the table detached. The table is fixed to the machine by means of a locating stud and retaining nut (see fig 3). As the table mounting stud and cradle are factory set, it is only necessary to position the table over the mounting stud and secure it by tightening the retaining nut using the spanner provided.

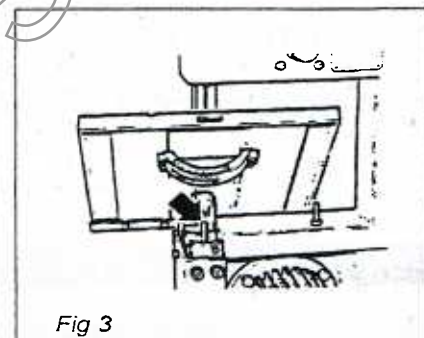

When moving and positioning this machine do not hold the table and drag it, always hold the spine or lower wheel box (see fig 4a and 4b). If moving long distances position the machine on a trolley before moving (see fig 4c).

Illustrations Fig 2 and Fig 4 show the machine fitted with the optional stand.

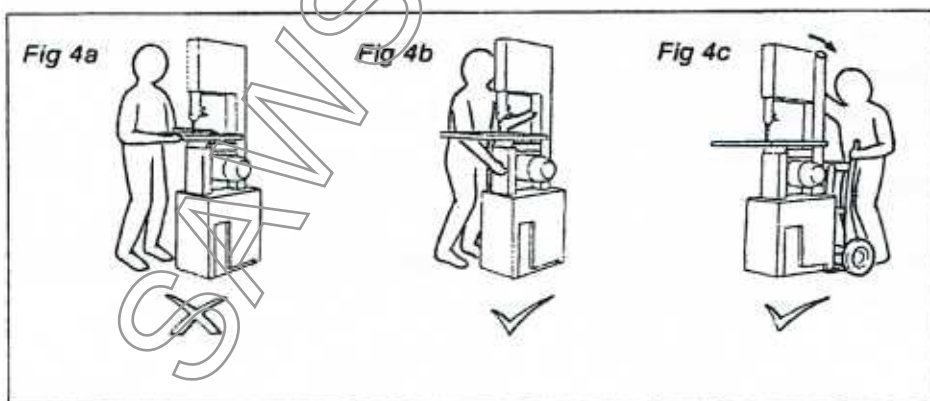

The machine should not be located in a confined space. Ensure that the working area is adequately lit. A cabinet located nearby is useful for the safe and secure storage of tools, blades and accessories.

The machine should be located on a solid surface that is level and fixed using four bolts (not supplied). Four mounting holes are provided in the base for this purpose. Ensure that the anticorrosive coating is removed from the table and other working parts used before use.

CONNECTION OF THE ELECTRICAL SUPPLY

The machine can only be connected to a single phase supply. Before connecting the electrical supply ensure that it is the correct voltage, phase and frequency, and that it has sufficient capacity for the machine. The relevant information can be found on the rating plate located on the rear of the machine (see fig 1).

Machines supplied for use in the UK are fitted with a BS 1363 plug fitted with a 13 amp fuse. Ensure that you use the appropriate plug for use in other countries. If the plug fitted to the machine is changed for any reason, the wires in the mains lead are coloured in accordance with the following code:

Green and yellow:	Earth
Blue:	Neutral
Brown:	Live

As the colours of the wires in the mains lead may not correspond with the coloured markings identifying the terminals in your plug, proceed as follows:

The wire coloured green and yellow must be connected to the terminal marked 'E' or by the earth symbol  or coloured green, or green and yellow.

The wire coloured blue must be connected to the terminal marked 'N' or coloured black.

The wire coloured brown must be connected to the terminal marked 'L' or coloured red.

IT IS IMPORTANT THAT THE MACHINE IS EFFECTIVELY EARTHED.

If in doubt about the connection of the electrical supply consult a qualified electrician.

CONNECTION TO A DUST EXTRACTION SYSTEM

The machine is fitted with an integral dust extraction outlet located at the rear of the machine. This can be accessed through the opening at the rear of the base (see fig 1). This is designed to accept 38mm dia. flexible hose (not supplied).

Simply insert one end of the flexible hose in the port, and connect the other end of the hose to inlet of a suitable dust extractor.

To ensure effective extraction, the flexible hose must be free of obstructions.

For effective extraction the recommended air flow speed is 20 to 25 m/s.

For further information on the use of dust extraction equipment contact the organisation from which the machine was purchased.

SETTING AND OPERATING INSTRUCTIONS

BEFORE ANY ADJUSTMENTS ARE MADE TO THE MACHINE, ENSURE THAT IT IS DISCONNECTED FROM THE ELECTRICAL SUPPLY

ADJUSTING TABLE TILT ANGLE

The table can be tilted up to 45°. To tilt the table, slacken the trunnion nut using the spanner provided (see fig 6). Tilt the table to the desired angle and then align the pointer with the protractor scale. Ensure the trunnion nut is securely tightened before using the machine.

When sawing with the table tilted ensure the work is adequately supported by using, for example, the rip fence or the optional mitre gauge.



Fig 6

ADJUSTING BLADE GUARDS

The upper and lower blade guards are fully adjustable. They should be adjusted to leave the minimum amount of blade exposed.

The upper blade guard can be adjusted by slackening the locking handle and sliding the guard assembly up or down to the desired position (see fig 7). Ensure the locking handle is securely tightened before sawing commences.

The lower blade guard can be adjusted when the table is tilted by releasing the retaining nut and adjusting to the required position (see fig 8). Ensure the locking nut is securely tightened before sawing commences.

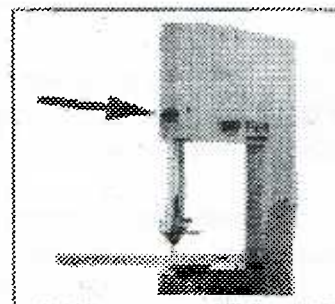

Fig 7

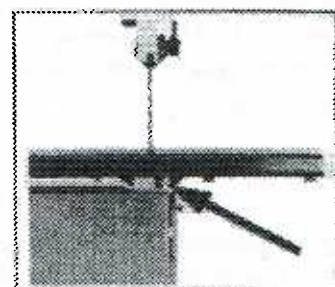

Fig 8

ADJUSTING THE BANDWHEEL BRUSH

For effective sawing it is important to ensure the lower bandwheel is kept free from dust and waste material. A bandwheel brush located near the top of the lower bandwheel is provided for this purpose. To adjust, slacken the retaining nut and slide the brush toward the bandwheel whilst applying pressure (approximately 1 kg) then tighten the retaining nut (see fig 9). Prior to operating the machine ensure that all fasteners are securely tightened. Replace the brush when the length of the bristles is less than 8mm.

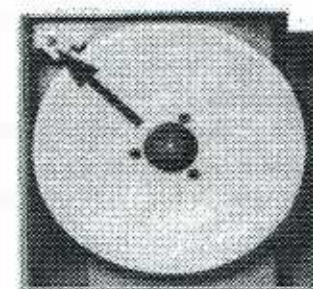

Fig 9

SETTING AND OPERATING INSTRUCTIONS

REPLACING THE TABLE INSERT

A plastic insert is fitted in the table (see fig 1) to ensure that the blade is not damaged should contact be made. When replacing the insert ensure that the slot is aligned with the slot in the table and that the top surface of the insert is flush with the table surface.

FITTING THE BLADE

To remove the blade open both bandwheel doors, remove the upper guard by slackening the retaining screw (see fig 10a), remove the lower blade guard by slackening the retaining nut (see fig 10b), and remove the fence rail by slackening the four retaining screws located beneath the front edge of the table (see fig 10c).

Release the blade tension by rotating the blade tension adjuster (see fig 1). Carefully lift the blade from the upper and lower bandwheels and slide it through the table slot and from under the fixed guard attached to the spine.

When replacing the blade position it centrally on the bandwheels ensuring it is not snagging on the fixed guard attached to the spine or the table slot. Also, ensure it is positioned between the upper and lower blade guides.

Whilst tensioning the blade it may be necessary to adjust the blade tracking to ensure the blade runs centrally on the bandwheels. Adjustment of tracking and tension is described below.

Having adjusted the blade tracking and tension replace the upper and lower guards and fence rail ensuring that all retaining screws are securely fastened. To ensure optimum cutting performance and blade life the rip fence should be aligned with the table slot by adjusting the position of the fence rail.

BLADE TENSION ADJUSTMENT

Blade tension is adjusted by rotating the blade tension adjustment (see fig 1). Rotate the adjuster clockwise to increase blade tension and anti clockwise to decrease blade tension (see fig 11).

BLADE TENSION INDICATION

Blade tension is shown by the blade tension indicator (see fig 12). The correct tension is dependent on the blade, material being sawn and the material thickness. More information is given in the section on blade selection later in this handbook (see table 2).

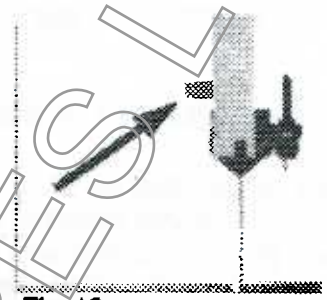

Fig 10a

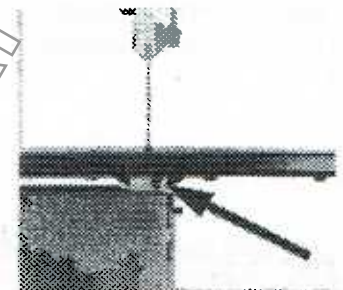

Fig 10b

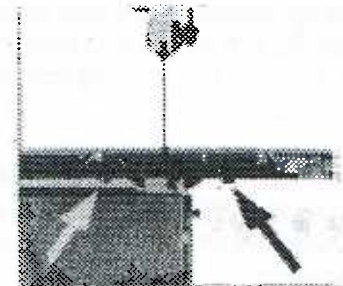

Fig 10c



Fig 11

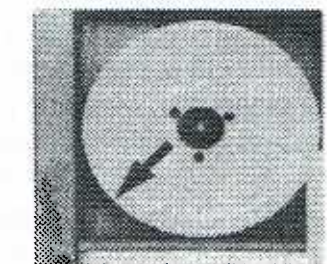

Fig 12

SETTING AND OPERATING INSTRUCTIONS (Continued)

BLADE TRACKING

It is important that the blade runs centrally on the bandwheels (see fig 13). To ensure this it may be necessary to adjust the blade tracking. This is done by releasing the lock nut securing the tracking adjuster located on the rear of the machine. When correctly adjusted secure the adjuster by fastening the lock nut.

After replacing a blade or adjusting the tracking it is important to ensure the upper and lower blade guides are correctly set. The adjustment of these is described below.

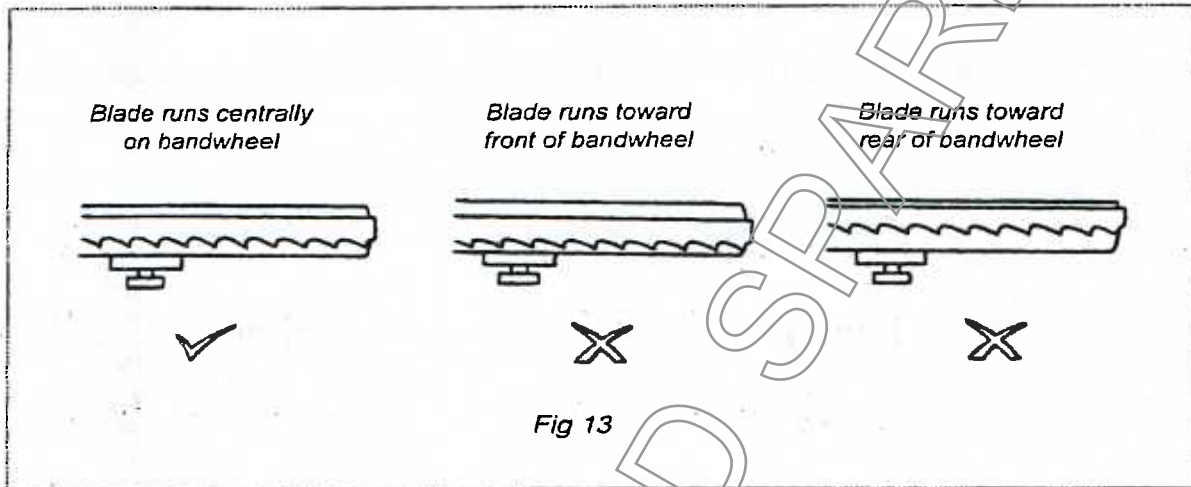

BLADE GUIDE ADJUSTMENT

The upper and lower blade guide system incorporates lateral guidance and back edge support. It is important that blade guides are set to provide the maximum support for the blade (see fig 14).

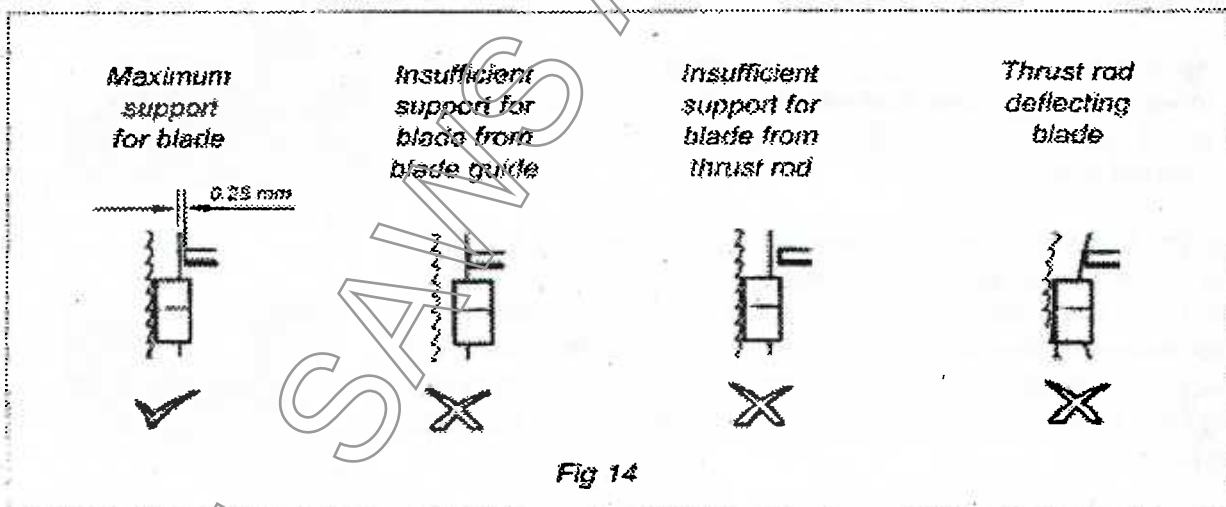

SETTING AND OPERATING INSTRUCTIONS (Continued)

The lateral guides are adjusted by loosening the retaining nuts and positioning them so that they just clear the gullet of the blade teeth and there is a gap of between 0.05mm and 0.10mm between the blade and the guide. The carbide tipped thrust support is adjusted by loosening the retaining screw and positioning the carbide tip to provide a gap of 0.25mm between the back edge of the blade and the end of the thrust support (see fig 15).

The height of the upper blade guide is fully adjustable. It should be adjusted to leave the minimum amount of blade exposed. The height of the upper blade guide can be adjusted by slackening the locking handle and sliding the guide assembly up and down to the desired position (see fig 7). Ensure the locking handle is securely tightened before the machine is switched on.

After adjustment ensure that all retaining screws and nuts are securely tightened before operating the machine.

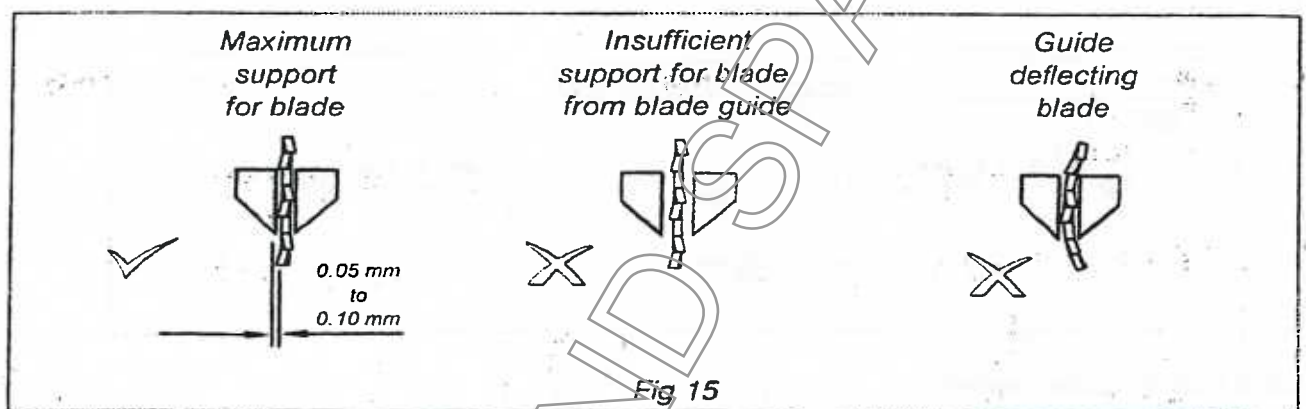

ADJUSTMENT OF RIP FENCE

A reversible dual height rip fence is provided to enable safe and accurate sawing of all thicknesses of material.

The fence assembly can be located on either side of the blade by slackening the fence retaining screw and relocating the fence assembly on the fence guide rail (see fig 17). Ensure the fence retaining screw is securely fastened before sawing.



Fig 17

To reverse the fence slacken the fence assembly retaining screw to remove the fence assembly from the fence guide rail (see fig 17) then remove the fence rail retainers to separate the fence clamp and fence body. After reversing the fence body securely tighten the fence rail retainers before repositioning the fence assembly on the fence guide rail (see fig 18). Ensure that all retaining screws are securely fastened before sawing.



Fig 18

SETTING AND OPERATING INSTRUCTIONS (Continued)

USING THE DEPTH STOP

The depth stop can be used in conjunction with the rip fence to assist in the production of tenons. The depth stop is attached to the rear edge of the table by passing the fixing screw through the slot and retainer, then fastening the retaining screw. The position of the stop is adjusted by slackening the locking screw located in the top of the retainer (see fig 18).

Ensure that all screws are securely tightened before use.

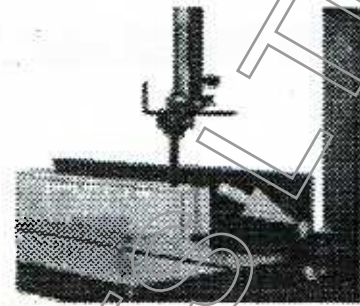

Fig 18

USING THE MITRE GAUGE

The mitre gauge is used to produce simple or compound angle cuts. After setting the angle of cut by slackening the locking screw located on the mitre gauge in the slot in the table. When cutting, ensure the work piece is securely held onto the face of the mitre gauge. Compound angles can be cut by tilting the table (see fig 19).

Ensure that all screws are securely tightened before use.

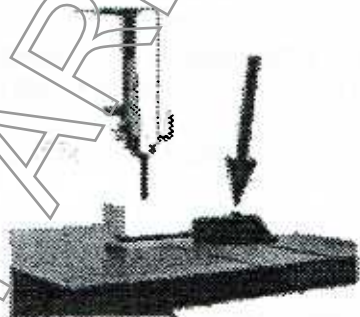

Fig 19

USING THE CIRCLE CUTTING ATTACHMENT

The circle cutting attachment is fixed to the mounting bracket located to the right of the upper blade guide assembly (see fig 20). Having sized the blank workpiece to be squared and oversize, mark the centre. It is important that the centre of the circle is level with the front edge of the blade. This is achieved by marking the rip fence with the position of the front edge of the blade, moving it to the right of the blade by a distance equal to the radius of the circle being cut, and positioning the pointer over the mark. Having made a cut parallel to one side of the blank until the blade reaches the circle, stop the machine and lower the pointer by lowering the guide assembly and tap the pointer into the workpiece. Finally, continue the cut to produce a circular blank.

Ensure that all fasteners are securely tightened before operating machine.

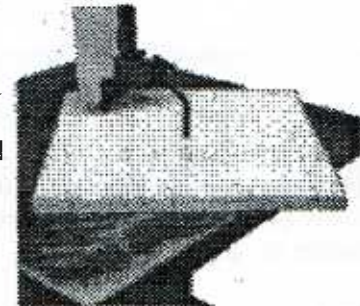

Fig 20

STARTING AND SAWING

Ensure that all guards are correctly adjusted and securely fixed, and that the fence is correctly positioned and secure.

The blade is set in motion by pressing the green start button located on the front of the machine (see fig 21).

Feed the workpiece with even and moderate pressure. If the feed pressure is too great cutting will be inaccurate and the blade will wear prematurely.

To avoid contact with the blade use a push stick to guide work past the blade.

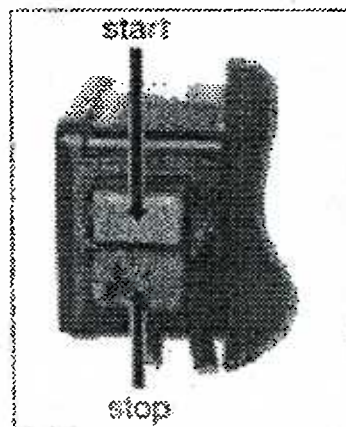

Fig 21

SETTING AND OPERATING INSTRUCTIONS (Continued)

STOPPING

The saw blade is stopped by depressing the red stop button located below the start control on the front of the machine (see fig 21).

MAINTENANCE

The frequency of maintenance is dependent on the frequency of use and the nature of the work undertaken. It is recommended that the following maintenance schedule is undertaken at least monthly to ensure trouble free operation. Ensure that the electrical supply is disconnected from the machine and that it has come to rest before undertaking any maintenance.

- Remove swarf, chips and dust from bandwheel tyres. Check for wear and replace bandwheel if necessary.
- Adjust bandwheel brush to ensure effective bandwheel cleaning.
- Clean dust from inside of bandwheel boxes and ensure dust extraction ducting is free from obstructions.
- Clean and check upper and lower guide assemblies for correct clearance and alignment. Replace if worn.
- Clean and lubricate adjusting screws with light machine oil.

Bandwheel hubs are mounted on sealed pre lubricated maintenance free bearings.

For genuine spare parts and service from fully trained engineers contact **A.L.T. Saws & Spares Ltd** CUSTOMER SERVICES or the organisation from which the machine was purchased. We can also supply blades for any application.

BLADE AND TENSION SELECTION

An understanding of the design and application of the various types of saw blades is important to enable the most effective use of your bandsaw. Table 1 provides recommendations on selecting the correct blade for a variety of commonly used materials.

SELECTION OF TOOTH PITCH

The selection of the best tooth pitch (see fig 22) is necessary for the optimum cutting performance. As the tooth pitch becomes finer a blade will have more teeth. Correct tooth pitch is primarily dependant on two factors: material thickness and material hardness. For a given material thickness a finer tooth pitch should be selected as material hardness increases. However, when the tooth pitch is too small for a given hardness the tooth loading will be insufficient to enable penetration and cutting and the teeth will rapidly lose their sharpness. A smaller tooth pitch should also decrease as material thickness decreases. The accompanying blade selection chart (table 1) gives guidance on the tooth pitch that should give the best results when cutting a variety of material types and thickness'.

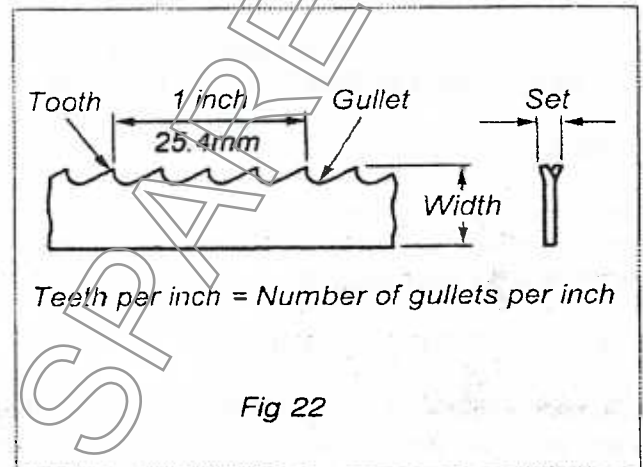

Fig 22

SELECTION OF TOOTH FORM

There are three most commonly specified tooth forms: regular tooth, skip tooth and hook tooth. Each will provide further improvement in cutting efficiency depending on the material being cut (see fig 23a, 23b and 23c). The blade selection chart (table 1) includes recommendations on the choice of suitable tooth forms.

Regular Tooth Blades (fig 23a)

These are the most commonly used blades for wood and metal cutting. The zero front rake and rounded gullets provide robust teeth with good shock resistance that are capable of good work penetration that will provide a good finish when used to cut most medium hardness materials. There is tendency to clog when used with soft or ductile materials. Standard pitches are 6, 8, 10, 14, 18 and 24 teeth per inch.

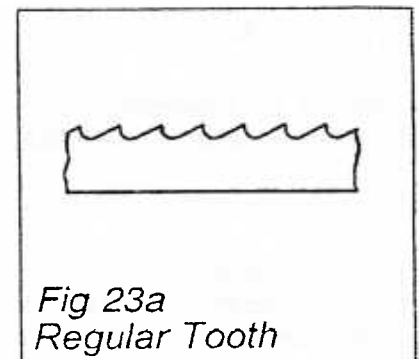

Fig 23a
Regular Tooth

Skip Tooth Blades (fig 23b)

The tooth form is similar to the regular tooth form but alternate teeth are omitted. This allows greater gullet capacity without significantly affecting the blade strength. These blades are suited for use with soft alloys or when making deep cuts in hard or wet wood, or man main materials that contain abrasive bonding agents (e.g. chipboard). For such applications best results can usually be achieved by selecting the low cutting speed. Standard pitches are 3, 4 and 6 teeth per inch.

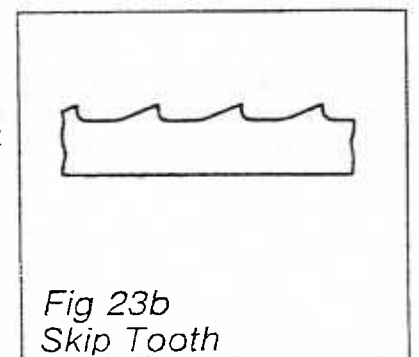

Fig 23b
Skip Tooth

BLADE AND TENSION SELECTION (Continued)

Hook Tooth Blades (fig 23c)

Compared to the regular tooth form the hook tooth has a positive front rake which provides greater work penetration capability. This makes such blades suitable for use when cutting harder materials. In addition the coarse pitch and large gullets associated with this tooth form make it suitable for sawing deep sections. Use with abrasive materials is not recommended. Standard pitches are 2, 3, 4, and 6 teeth per inch.

Other less commonly used blade forms are knife edge, scalloped edge and wavy edge (see fig's 24a, 24b and 24c).

Knife Edge Blades

This type of blade is suited for use when cutting soft materials such as woven fabrics, sponge, rubber and corrugated cardboard. Very little swarf or dust is produced.

Scallop and Wavy Edge Blades

Where the material being cut is fibrous or difficult to sever scallop or wavy edge blades provide better cutting performance. Examples of such materials are cork, filter material and felt. Very little swarf or dust is produced.

SELECTION OF TOOTH SET

Tooth set is the angling of the saw blade teeth which results in them protruding either side of the main body of the saw blade. Tooth set provides a cut that is wider than the width of the blade body. This clearance enables the blade to be manoeuvred in the work piece. There are three commonly used tooth set patterns. Recommended set is given for a variety of material types and thicknesses in table 1.

Standard Set

Teeth are set alternately to the left and to the right of the blade body. This pattern is particularly suitable for cutting soft materials and wood.

Raker Set (fig 25)

Teeth are set with one tooth set to the right, one to the left followed by one unset tooth. This pattern is widely preferred and is considered suitable for contour sawing.

Wavy Set (fig 25)

Groups of teeth are alternatively set to the right and then to the left. As relatively few teeth are cutting on the kerf side of the blade there is a tendency for blades to jam when cutting abrasive materials.

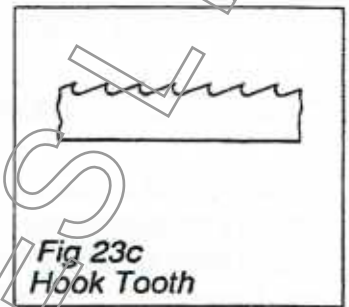

Fig 23c
Hook Tooth

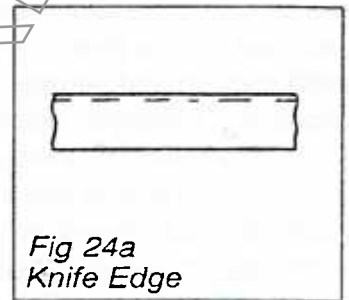

Fig 24a
Knife Edge

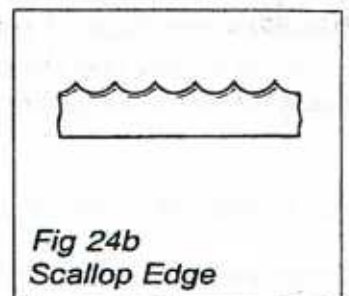

Fig 24b
Scallop Edge

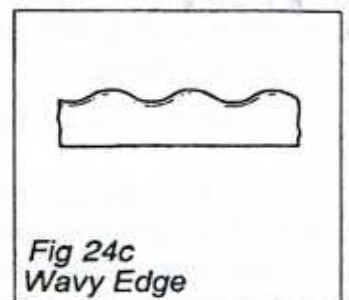

Fig 24c
Wavy Edge

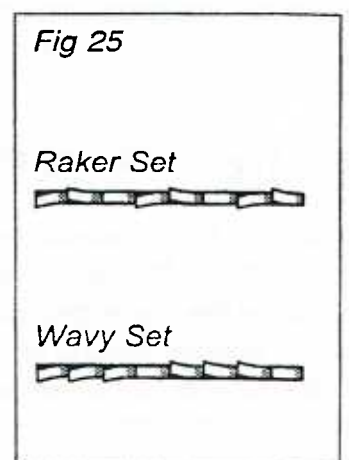

Fig 25

Raker Set

Wavy Set

BLADE AND TENSION SELECTION (Continued)

For optimum cutting performance it is important to select the correct blade. Table 1 shows the recommended blade for a variety of commonly used materials. If in doubt about any aspects of blade selection contact **A.L.T. Saws & Spares Ltd**

Table 1 Blade Selection Chart

Material	Material Thickness, t (mm)			
	t<6	6<t<12	12<t<25	t>25
Aluminium extrusion	18R	10R	8R	6S
Thermoset plastic (Bakelite)	14R	10R	6R	3S
Resin bonded comp (Tufnol)	14R	10R	6H	
Formica	18R			
Glass Fibre	18R	14R	10R	6H
Perspex	14R	10R		
Chipboard		6S	3S	3S
Fibre board	18R	14R		
Hardboard	10R			
Plywood	10R	8R	6S	3S
Strawboard	14R	10R		
Cork	14R	6S	4S	4S
Leather	14R			
Rubber	10R	8R		
Cardboard - corrugated	SC	SC	SC	SC
Paper - sheet	10R	6H	10R	6H
Paper - tissue	SC	SC	SC	SC
Papier mache	KN	10R		
Wood - log				3S
Wood - soft	6S	6S	4S	4S
Wood - hard	6S	3S	3S	3S
Wood - wet				3S

Key

R = Regular tooth

S = Skip tooth

H = Hook tooth

KN = Knife edge

SC = Scallop edge

Numbers denote teeth per inch

BLADE AND TENSION SELECTION (Continued)

TENSION SELECTION

It is important that the blade is correctly tensioned to ensure optimum cutting performance and cutting accuracy. Table 2 below provides guidance on the appropriate tension for a variety of blade types and sizes.

Table 2 Blade Tension Guide

Blade Type	Blade Width (mm)			
	3	6	12	20
Metal Cutting	Low	Low	Med	High
Scalloped/Knife Edge	Low	Low	Low/Med	Med/High

BANDSAWING PRACTICE

Having selected an appropriate blade for the particular thickness and type of material to be sawn, it is essential that the saw blade is allowed to cut freely by not applying too much pressure. The need for excessive pressure is likely to be a result of the incorrect blade selection or a worn blade and will result in inaccurate cutting and possibly blade breakage.

When contouring the width of the blade limits the minimum radius that can be cut. If the blade is too wide for the cutting radius the blade will twist and possibly jam or break. The smaller the radius the narrower the blade has to be. Table 3 provides guidance on the minimum radius to be cut with the most commonly used blade widths. Regularly examine the blade for excessive damage or cracking as a result of fatigue. If such damage is present replace the blade.

It is important to use a sharp blade. Dull teeth result in increased feed pressure producing a poor quality finish and an inaccurate cut.

Table 3 Minimum Cutting Radius

Blade Width (mm)	3	6	10	12	16	20
Minimum Radius (mm)	10	25	40	60	100	135

In situations such as cutting scrolls it may not be possible to complete a cut. This requires the blade to be reversed out of the cut. Care is necessary to minimise damage to the work and blade. When removing large pieces of material it is advisable to make the shorter cut last to avoid having a reverse out of the longer cut.

Very complicated cuts and small radius curves are the best accomplished with the aid of pre-drilled holes combined with a few tangential or radial cuts. This technique will achieve excellent results without putting undue tension on the blade and blade guide assembly.

Always ensure that your machine is properly maintained and clean.

Before commencing work on an important project, it is advisable to familiarise yourself with the operation of the equipment by practising on low value materials.

When cutting aluminium alloys it may be necessary to apply lubricant such as paraffin or wax to prevent clogging of the blade.

COMMON SAWING PROBLEMS

PROBLEM	POSSIBLE CAUSE	REMEDY
Blade wanders from true line	Excessive feed pressure Dull teeth or pitch too fine Blade guides not set correctly or worn Blade tracking incorrectly Loss of set to one side of blade	Reduce feed pressure Replace blade Adjust or replace upper and lower guides Adjust tracking Investigate cause and replace
Premature blade breakage	Worn blade Joint incorrectly welded or annealed Blade too wide for curved cut Bandwheels worn Tooth pitch too fine	Replace blade Replace blade Fit narrower blade Change bandwheels Fit blade with coarser pitch
Blade bows in deep cut	Excessive feed pressure Dull teeth or pitch too fine Insufficient blade tension Blade too narrow for depth of cut Blade running out of line at start of cut	Reduce feed pressure Fit new blade or blade with coarser pitch Increase blade tension Fit wider blade Restart cut
Teeth dull rapidly	Insufficient feed pressure Guide inserts interfering on teeth Blade pitch too fine	Increase feed pressure Adjust Guides Fit blade with coarser pitch
Teeth break from blade	Excessive feed pressure Tooth gullies clogging Tooth pitch too coarse Material welding to teeth	Reduce feed pressure Use lubricant or change tooth form Fit blade with finer tooth pitch Use lubricant
Blade twisting	Excessive feed pressure Blade guide interfering with teeth Blade too wide for radius cut	
Blade vibrates	Workpiece not secured or properly seated Tooth pitch too coarse Insufficient blade tension Blade not adequately supported by thrust pad	Secure or clear obstruction Fit blade with finer pitch Increase blade tension Adjust thrust pad

WIRING DIAGRAM

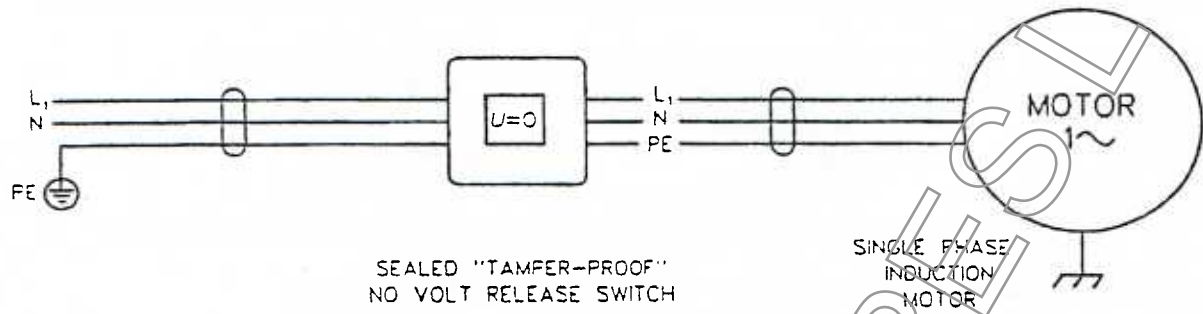

RCD (Residual Current Device)

For your additional safety we always recommend the use of an RCD (sometimes called Residual Current Circuit Breaker or Earth Leakage Circuit Breaker).

UPPER BANDWHEEL BOX, BLADE GUARD, GUARD AND TABLE

Item	Part No	Description	Qty
1	10162	Bandwheel Hub Spindle	1
3	BO2047	Bearing	2
4	10163	Bandwheel Hub	1
5	BO6003	External Circlip	1
6	BO5917	Washer	19
7	BO5560	Hexagon Head Screw	7
8	2473	Bandwheel	1
9	SM2853	Upper Blade Guard	1
10	4891	Blade Guard	2
11	BO5715	Nut	11
12	6756	Table Insert	1
13	4919	Washer	1
14	BO5621	Coach Bolt	2
15	SM1434	Guide Bracket	1
16	BO5923	Washer	1
17	BO5566	Hexagon Head Screw	1
18	5496	Guard Retainer	1
19	BO5208	Hexagon Socket Set Screw	2
20	BO5210	Hexagon Socket Set Screw	1
21	10237	Top Guide Post	1
22	BO2208	Spring	1
23	4988	Special Nut	1
24	BO2557	Clamping Handle	1
25	BO5620	Coach Bolt	4
26	6705	Pivot Pin	1
27	BO5930	Locking Washer	2
28	SM1676	Tracking Channel	1
29	BO5922	Washer	1
30	BO5777	Self Locking Nut	1
31	10372	Tension Screw	1
32	10371	Trunnion Nut	1
33	BO5733	Slotted Nut	1
34	BO5919	Washer	3
35	7834	Spring Plate	1
36	BO2241	Disc Spring	22
37	SM1675	Guide	1
38	BO2530	Ball Knob	1
39	BO5370	Locking Pin	1
40	6706	Tracking Lock Knob	1
41	5352/B	Stud	1
42	BO5753	Lock Nut	1
43	BO2545	Hand Knob	1
44	BO5016	Cap Screw	2
45	CYUW	Upper Door	
46	7354	Tension Indicator Plate	1
47	BO7782	Pivot Brush	1
48	BO5547	Hexagon Head Screw	1
49	BO5913	Washer	3
50	BO5773	Lock Nut	2
51	7878	Tension Plate	1
52	BO5713	Nut	2
53	BO5929	Spring Washer	2
54	10364	Table	1
55	10841	Fence Rail	1
56	CXSW	Start Stop Switch	1
57	SM585/A	Upper Thrust Rod	1
58	BO5203	Hexagon Socket Set Screw	1
60	BO5929	Star Washer	1
61	BO5952	Fibre Washer	1
62	BO5069	Cap Screw	1
63	10843	Table Latch	1
64	PC00066	Stud	2
65	BO5731	Binx Nut	1

UPPER BANDWHEEL BOX, BLADE GUIDE AND GUARD, AND TABLE

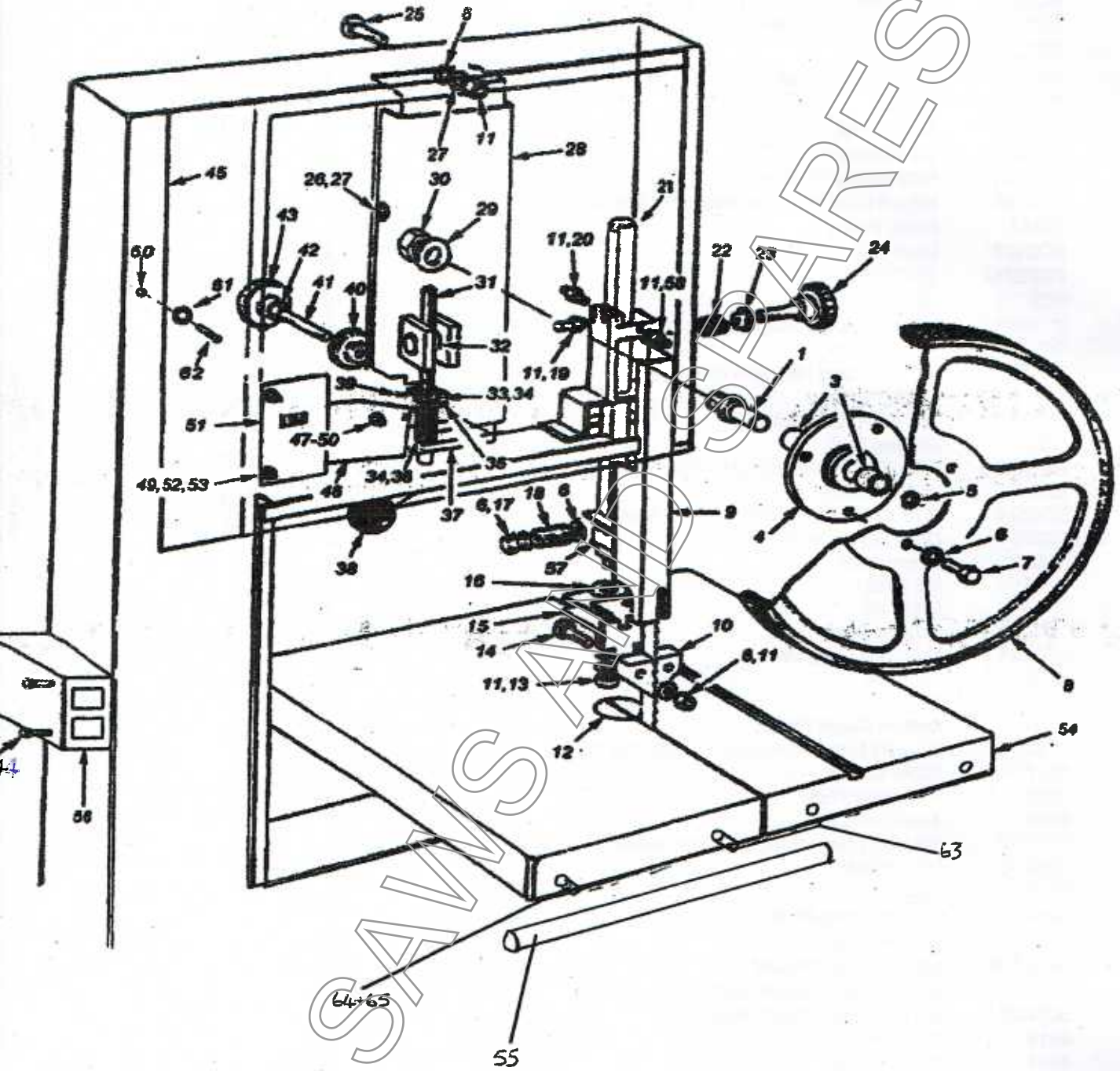

PARTS LIST - 351E (Continued)

LOWER BANDWHEEL BOX, BLADE GUIDE AND GUARD, AND MOTOR MOUNTING

Item	Part No:	Description	Quantity
1	BO5777	Binx Nut	1
2	BO5922	Washer	1
3	10162	Bandwheel Hub Spindle	1
5	BO2047	Bearing	2
6	10204	Bandwheel Pulley	1
7	BO6003	Circlip	1
8	2473	Bandwheel	1
9	BO5917	Washer	15
10	BO5931	Spring Washer	3
11	BO5186	Hexagon Socket Set Screw	1
12	10352	Motor Pulley	1
13	BO2161	Drive Belt	1
15	PC00012	351E Motor	1
16	BO5715	Nut	6
17	BO5564	Hexagon Head Screw	1
18	BO5919	Washer	3
19	BO5560	Hexagon Head Screw	3
20	10214	Motor Platform	1
21	BO5764	Lock Nut	1
22	7824	Jacking Bolt	1
23	BO5568	Hexagon Head Screw	1
24	2270	Wheel Brush	1
25	BO5574	Hexagon Head Screw	3
27	BO5871	Drive Screw	2
28	CYLW	Lower Door	1
29	BO5753	Lock Nut	1
30	BO5717	Nut	3
31	BO5921	washer	3
32	BO5841	Stud	3
33	4884	Tilt Plate	2
34	4885	Spacer	1
35	4890	Bottom Guide Holder	1
36	BO5075	Hexagon Socket Cap Screw	4
37	4911	Table Clamp	1
39	4921	Protractor Plate	1
40	4838	Table Bracket	1
41	BO5552	Hexagon Head Screw	1
42	BO5915	Washer	2
43	2812	Pointer	1
44	4888	Bottom Guide Post	1
45	BO5923	Washer	1
46	SM829/B	Lower Guide Bracket	1
47	BO5621	Coach Bolt	1
48	BO5622	Coach Bolt	1
49	4919	Washer	1
50	4891	Blade Guide	2
51	6748	Bottom Guard	1
52	BO5785	Wing Nut	1
53	SM585/B	Lower Thrust Rod	1
54	BO5929	Star Washer	1
55	BO5716	Nut	3
56	BO5952	Fibre Washer	1
57	7826	Spacer	2
58	BO5069	Cap Screw	1

PARTS LIST - 351E (Continued)

LOWER BANDWHEEL BOX, BLADE GUIDE AND GUARD, AND MOTOR MOUNTING

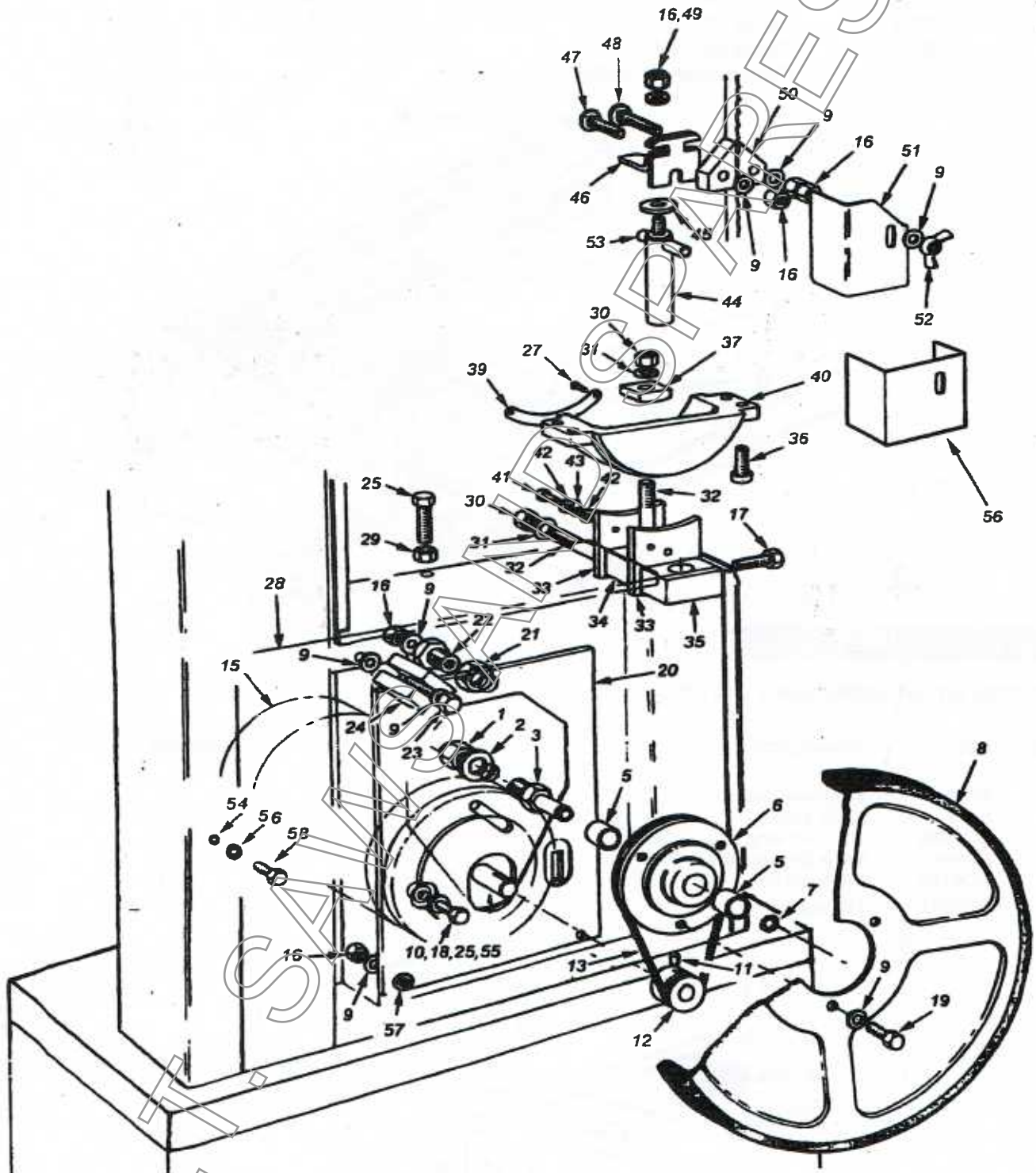

PARTS LIST - 352S

RIP FENCE ASSEMBLY SM4027

Item	Part No	Description	Qty
1	7338/D	Rip fence	1
2	PC00138	Cap Screw	2
3	4919	Washer	1
4	BO2545	Handwheel	1
5	BO2551	Handknob	1
6	10840	Fence block	1
7	10842	Fence support	1
8	SM1795	Clamp plate assembly	1

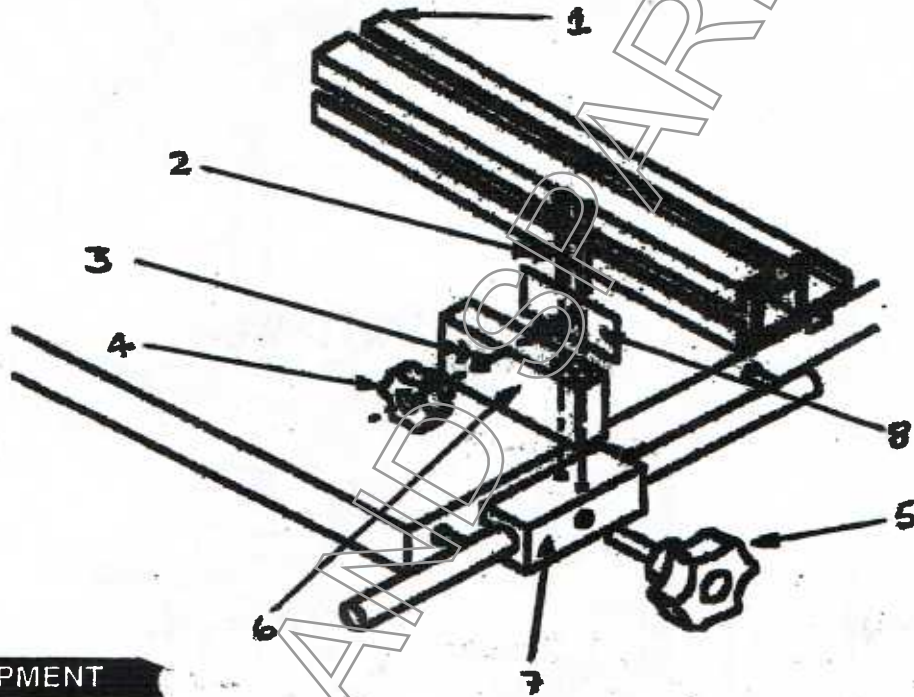

OPTIONAL EQUIPMENT

DEPTH STOP ASSEMBLY SM1436

Item	Part No.	Description	Quantity
1	6747	Clamping block	1
2	6749	Back stop rod	1
3	BO5826	wing screw	1
4	BO5621	coach bolt	1
5	BO5785	wing nut	1
6	BO5917	washer	1

